

Real Time Implementation of FMCW Radar for Target Detection using GNU Radio and USRP

Sundaresan S, Anjana C, Tessy Zacharia, Gandhiraj R

Abstract—Nowadays, FMCW (Frequency Modulated Continuous Wave) radar is widely adapted due to the use of solid state microwave amplifier to generate signal source. The FMCW radar can be implemented and analyzed at low cost and less complexity by using Software Defined Radio (SDR). In this paper, SDR based FMCW radar for target detection and air traffic control radar application is implemented in real time. The FMCW radar model is implemented using open source software and hardware. GNU Radio is utilized for software part of the radar and USRP (Universal Software Radio Peripheral) N210 for hardware part. Log-periodic antenna operating at 1GHZ frequency is used for transmission and reception of radar signals. From the beat signal obtained at receiver end and range resolution of signal, target is detected. Further low pass filtering followed by Fast Fourier Transform (FFT) is performed to reduce computational complexity.

Index Terms— Beat signal, GNU Radio, Log-periodic dipole antenna, Radar, USRP N210.

I. INTRODUCTION

RADAR networks have become common in most of the developed countries from the past decades. The radar operates by transmitting directional pulses of microwave radiation using a cavity magnetron or klystron tube connected by a waveguide to antenna. The radio frequency signal is transmitted and reflected from the target. A Portion of signal reflected from target returns to the radar, known as ECHO. The direction of target object and distance is calculated from ECHO signals [1]. The radar signal is generated by a powerful transmitter which includes magnetron or klystron and received by a highly sensitive receiver, resulting in high cost, therefore

radar researchers have proposed a new type of radar namely FMCW radar which can be implemented in low cost. At present, this type of radar is used widely, because the radar uses the emerging technologies to generate signals. Moreover, the SNR can be increased easily while, the power level and complexity is reduced in FMCW radar. The continuously modulated signal source is operated by modest power in FMCW radar [2], [3].

In this paper, the FMCW radar is utilized through both hardware and software source. Here, GNU Radio and USRP N210 with Log-periodic antenna to transmit and receive radar signals acts as software and hardware part respectively. Implementation of wireless communication system using Software Defined Radio (SDR) is open source and one of the emerging research areas. SDR is a technique for high speed wireless applications with minimal hardware devices and also cost efficient [4]–[6]. In FMCW radar, beat signal is obtained from the transmitted and received signal difference, from which the range detection of target is determined. Delay blocks are used for range detection of targets with different values.

This paper is organized as follows. Section II explains the principles and theory of FMCW radar. Next, Section III briefs about the mathematical background of FMCW radar. Section IV discusses about the implementation of FMCW radar in real time using GNU Radio and USRP N210 connected with Log-periodic antenna, and Section V is focused on the results and discussions. Section VI presents the conclusions, followed by future work of this paper.

II. FMCW RADAR PRINCIPLES AND THEORY

FMCW Radar transmits a continuous carrier, which is modulated by a periodic function viz., sawtooth or sinusoidal wave to provide range data. Fig. 1 shows the block diagram of FMCW radar system. The chirp generator acts as the signal source at the transmitter and mixer input of receiver too. Voltage Controlled Oscillator (VCO) present in chirp generator controls the oscillation frequency by a voltage input which is generated by D/A converter. Antennas are the transitional structure between free-space and guiding device. Bistatic radar consumes two antennas for transmitting and receiving. The signals get illuminated on targets through transmitter front end which is then reflected back and received by the receiver front end. Low Noise Amplifier (LNA) at the receiver end amplifies the weak signal with high gain and low

Sundaresan S is with the Remote Sensing and Wireless Sensor Networks (CEN), Amrita Vishwa Vidyapeetham, Coimbatore-641112, Tamilnadu, India. (Mobile: 999-466-3670; e-mail: sundaresanece91@gmail.com).

Anjana C is with the Remote Sensing and Wireless Sensor Networks group (CEN), Amrita Vishwa Vidyapeetham, Coimbatore-641112, Tamilnadu, India. (Mobile: 974-698-4421; e-mail: anjana4421@gmail.com).

Tessy Zacharia is with the Remote Sensing and Wireless Sensor Networks (CEN), Amrita Vishwa Vidyapeetham, Coimbatore-641112, Tamilnadu, India. (Mobile: 974-698-4421; e-mail: tessyzacharia43@gmail.com).

Gandhiraj R is with the Department of Electronics and Communication Engineering, Amrita Vishwa Vidyapeetham, Coimbatore-641112, India. (e-mail: r_gandhiraj@cb.amrita.edu).

noise figure [7], [8].

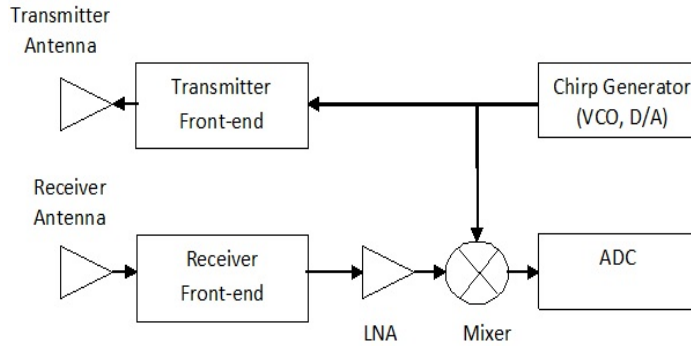

Fig. 1. Block Diagram of FMCW Radar

The signal from LNA is mixed with reference signal using mixer which acts as a multiplier. The high frequency signal from the mixer is low pass filtered for reducing the computational load. The FMCW waveform is obtained by frequency modulating the carrier signal with the periodic linear signal. The chirp signal is given as

$$f(t) = f_0 + f_t t \quad (1)$$

where f_0 is initial frequency, f_t is chirp rate ($f_t = B/T$), and T is the duration of a chirp signal [9]. The waveform representation of FMCW signal in the time domain is shown in Fig. 2. Frequency difference between transmitted and received signals is shown in Fig. 3. Pulse Repetition Interval (PRI) is the duration of signal repetition, B is the bandwidth of transmitted signal, t_{delay} is the delay between transmitted and received signals. The beat frequency of FMCW radar gives the range of target and also relative radial velocity [9], [10].

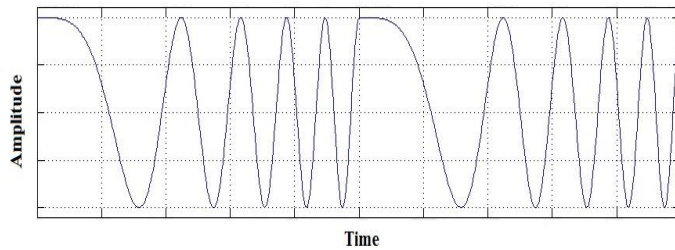

Fig. 2. FMCW Radar Waveform in Time Domain

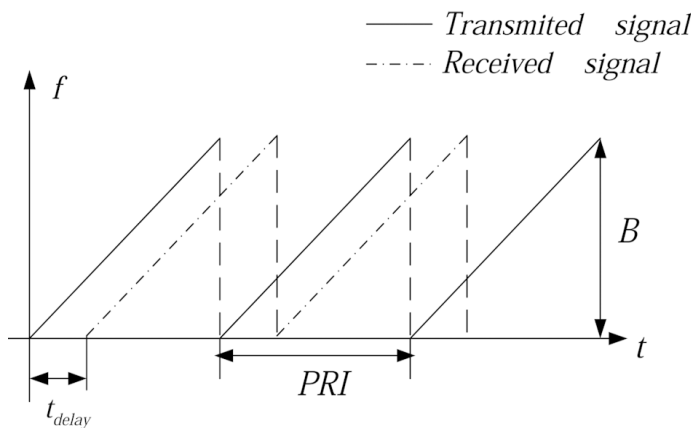

Fig. 3. Frequency Difference between Transmitted and Received Signals

III. FMCW RADAR MATHEMATICAL BACKGROUND

FMCW radar transmits continuous microwave signal that is linear frequency modulated. Transmitted signal is illuminated towards the target and reflected signal is obtained at the receiver end with a propagation time delay and resembles to be a copy of transmitted signal. The propagation delay is given by

$$\tau = 2R / C \quad (2)$$

where R is an object range, and C is the speed of light. FMCW radar range resolution is given by

$$\Delta R = \frac{c}{2B} \quad (3)$$

where c is the speed of light and B is the bandwidth of transmitted frequency. The range of the target is calculated from (4) in which Δf is the difference between transmitted and received signal and T is the time period of chirp signal [9].

$$r = \frac{c \Delta f T}{2B} \quad (4)$$

The range information in FMCW radar gets affected by the error factor due to Doppler Effect of the target. This error is corrected by determining the velocity value. From the Fourier spectrum of the signal $x(t)$, the range information is obtained and given by (5) and is computed for one (k -th) modulation period.

$$X_\tau(\omega, k) = \int_{-\frac{T}{2} + \tau_{mx}}^{\frac{T}{2}} x(t_k) e^{-j\omega t_k} dt_k \quad (5)$$

Where ω is the angular frequency, $t_k = kT$ in which $k=0, 1, \dots, K-1$, T is the sampling period, τ is the propagation time, τ_{mx} is the delay of reflected signal from target at the range of radar [7], [9].

IV. GNU RADIO IMPLEMENTATION OF FMCW RADAR WITH USRP N210

FMCW radar is implemented in real time with less complexity and cost efficiently using Software Defined Radio (SDR) platform. Nowadays, SDR is one of the emerging areas of research through which communication systems can be analyzed and studied in low cost and accuracy [11], [12]. FMCW radar is modeled both in hardware and software domain. The components utilized in FMCW radar are chirp generator, transmitter, receiver, mixer blocks, USRP N210 and Log-periodic antenna of range 400-1000 MHz with high directivity [13]–[15]. In this paper, frequency of 1 GHz is utilized for transmission and reception of radar signals. The particular choice of the frequency is used due to the target detection application Viz., Air Traffic control radar.

The GNU Radio transmitter and receiver blocks of the FMCW radar system is shown in Figs. 4 and 5 (Refer Annexure). The overall flow of the system is as follows; the *Signal Source* is used for generating sawtooth signal and it is frequency modulated using *VCO* block, which results in chirp signal. *Hilbert Transform* block is used for real to complex

transformation of the signal, since; the transmitted signal needs to be in complex form. This complex signal is sent to the USRP N210 connected with Log-periodic antenna through *UHD sink* block.

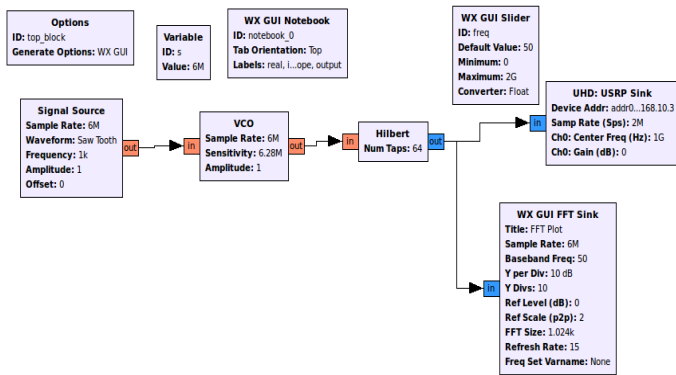

Fig. 4. GNU Radio FMCW Radar Transmitter Blocks

The complex signal after illuminated towards target gets reflected and portion of the signal is captured by Log-periodic antenna connected to USRP N210 through *UHD source*. This complex signal is converted back to real signal using *Complex To Real* block and given as input to *Multiply* block. This block acts as mixer and the output obtained will be the Beat signal. This Beat signal is saved into a binary float file using *Skip Head* and *Head* blocks.

The range resolution of target detected depends on the gain of antenna, center frequency used and the radial velocity of target. Beat signal or beat frequency is called the range to the target, which is proportional to the difference between the signals. The target detection in FMCW radar system is not only restricted for single target but even more. Fig. 6 (Refer Annexure) depicts the GNU radio block of FMCW radar with *Delay* blocks to simulate the delay caused by the reflection from a target. Each delay element introduces certain delay in beat signal from which the range and target detection is made. The beat signal contains complex data, hence it is low pass filtered followed by FFT in order to reduce complexity in computation. Table I summarize the FMCW radar specifications used for target detection.

TABLE I
FMCW RADAR DESIGN SPECIFICATIONS

Parameters	Values
Frequency	1GHz
Chirp Frequency	0.75MHz
Chirp Waveform	Sawtooth
Sampling Rate	6MS/s
Chirp Period	1ms

V. RESULTS AND DISCUSSION

From the resultant plot it is observed that, FMCW radar is able to perform target detection within the range of antenna using the frequency component of the beat signal. Fig. 7 shows the beat signal for single target before performing Low Pass

Filtering (LPF) and Fourier transform (FFT). Fig. 8 depicts the FFT plot of single target within the range of radar. The single peak is due to single frequency corresponding to reflectivity and range.

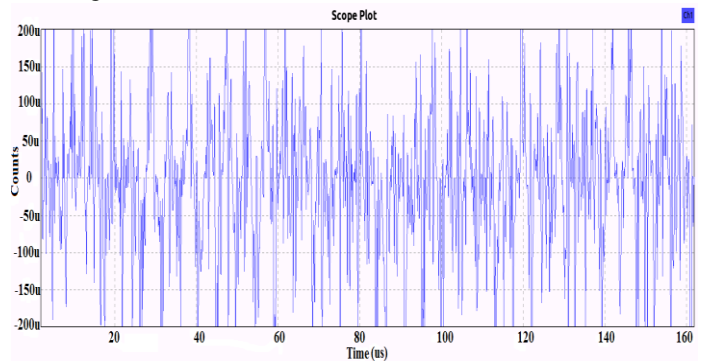

Fig. 7. Beat Signal for Single Target

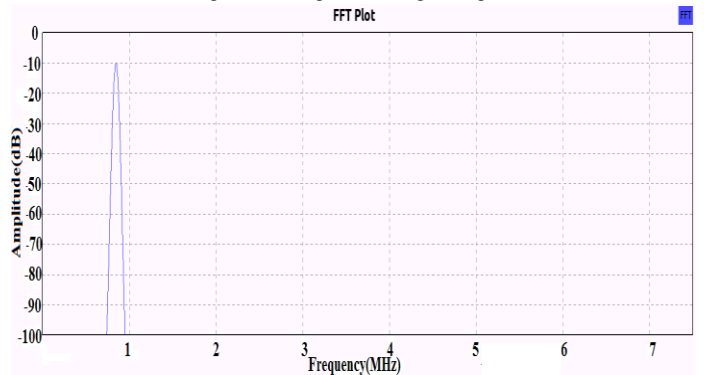

Fig. 8. Frequency Spectrum of Beat Signal for Single Target

Fig. 9 shows the beat signal for two different targets with delay elements which produces propagation delay in different intervals and the frequency spectrum for two targets in range is depicted in Fig. 10. The two peaks in the plot correspond to two different targets with different time delays. The amplitude of the frequency for both the peaks should be same theoretically. But the unequal amplitude is due to skewing and nonlinearity in FMCW radar system.

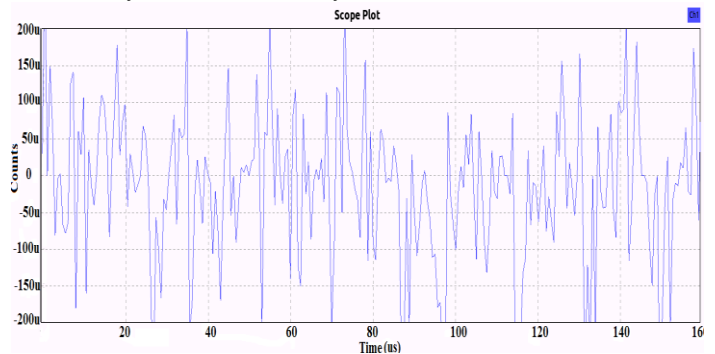

Fig. 9. Beat Signal for Two Targets

VI. CONCLUSIONS AND FUTURE WORK

Real time implementation of FMCW radar using GNU Radio and USRP N210 with Log-periodic antenna is implemented in real time for single and two targets detection. The choice of SDR based FMCW radar is made because; the analysis and study can be done with less complexity and low cost. The operating frequency of FMCW radar is chosen to be

1GHz (L-band) with sawtooth waveform as chirp signal. With proper design and high power, this FMCW radar system can be utilized for air traffic control radar system. Future work can be on performance improvement of FMCW radar to detect more targets and increasing the range and resolution of the radar. Further work can be done on imaging of radar for exact identification of targets.

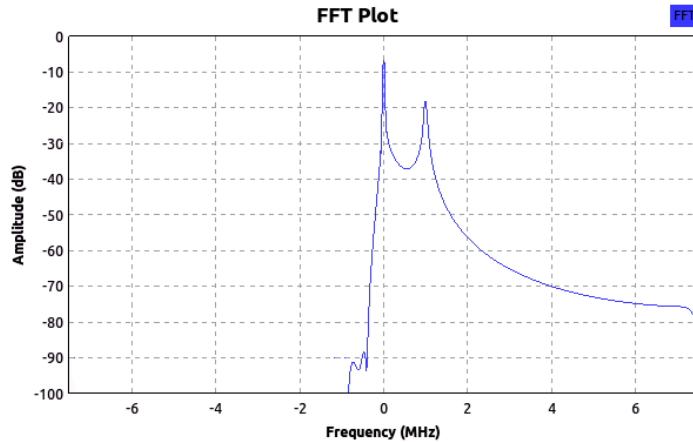

Fig. 10. Frequency Spectrum of Beat Signal for Two Targets

REFERENCES

[1] W. Melvin and J. Scheer, *Principles of modern radar*. The Institution of Engineering and Technology, 2012.
 [2] V. Winkler, "Range Doppler detection for automotive FMCW radars," in *Microwave Conference, 2007. European*, 2007, pp. 1445–1448.
 [3] M. Jankiraman, *Design of multi-frequency CW radars*. SciTech Publishing, 2007.
 [4] R. Gandhiraj, R. Ram, and K. P. Soman, "Analog and digital modulation toolkit for software defined radio," *Procedia Eng.*, vol. 30, pp. 1155–1162, 2012.

[5] M. Abirami, V. Hariharan, M. B. Sruthi, R. Gandhiraj, and K. P. Soman, "Exploiting GNU radio and USRP: an economical test bed for real time communication systems," in *2013 Fourth International Conference on Computing, Communications and Networking Technologies (ICCCNT)*, 2013, pp. 1–6.
 [6] S. Sriram, G. Srivasta, R. Gandhiraj, and K. P. Soman, "Plug-ins for GNU Radio Companion," *Int. J. Comput. Appl.*, vol. 52, no. 16, pp. 11–16, 2012.
 [7] A. Meta, P. Hoogeboom, and L. P. Ligthart, "Signal processing for FMCW SAR," *Geosci. Remote Sens. IEEE Trans. On*, vol. 45, no. 11, pp. 3519–3532, 2007.
 [8] S. Ayhan, M. Pauli, T. Kayser, S. Scherr, and T. Zwick, "FMCW radar system with additional phase evaluation for high accuracy range detection," in *Radar Conference (EuRAD), 2011 European*, 2011, pp. 117–120.
 [9] A. Prabaswara, A. Munir, and A. B. Suksmono, "GNU Radio based software-defined FMCW radar for weather surveillance application," in *Telecommunication Systems, Services, and Applications (TSSA), 2011 6th International Conference on*, 2011, pp. 227–230.
 [10] A. E. Prasetiadi and A. B. Suksmono, "A simple delay compensation system in software-defined Frequency Modulated Continuous (FMCW) Radar," in *European Wireless, 2012. EW. 18th European Wireless Conference*, 2012, pp. 1–4.
 [11] K. Woodbridge, K. Chetty, L. Young, N. Harley, and G. Woodward, "Development and demonstration of software-radio-based wireless passive radar," *Electron. Lett.*, vol. 48, no. 2, pp. 120–121, 2012.
 [12] R. Anand, G. Xavier, V. Hariharan, N. Prasannan, R. Peter, and K. P. Soman, "GNU Radio Based Control System," in *Advances in Computing and Communications (ICACC), 2012 International Conference on*, 2012, pp. 259–262.
 [13] T. Ajitha, E. Joy, A. AnishJoyce, and R. Gandhiraj, "Radiation pattern measurement of log-periodic antenna on GNU Radio platform," in *Green Computing Communication and Electrical Engineering (ICGCCCE), 2014 International Conference on*, 2014, pp. 1–4.
 [14] R. Chauhan, "A Platform for False Data Injection in Frequency Modulated Continuous Wave Radar," UTAH STATE UNIVERSITY, 2014.
 [15] M. B. Sruthi, R. Gandhiraj, and K. P. Soman, "Realization of wireless communication system in SDR using GNU radio," *Int J Adv Res Comput Sci Softw Eng*, vol. 3, no. 6, 2013.

ANNEXURE

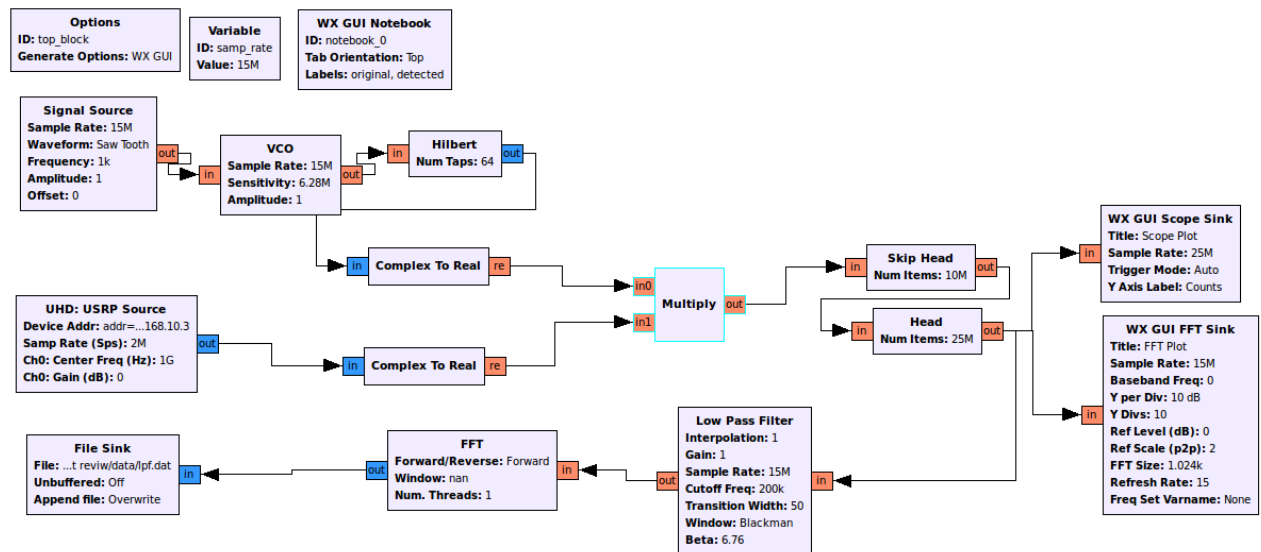

Fig. 5. GNU Radio FMCW Radar Receiver Blocks

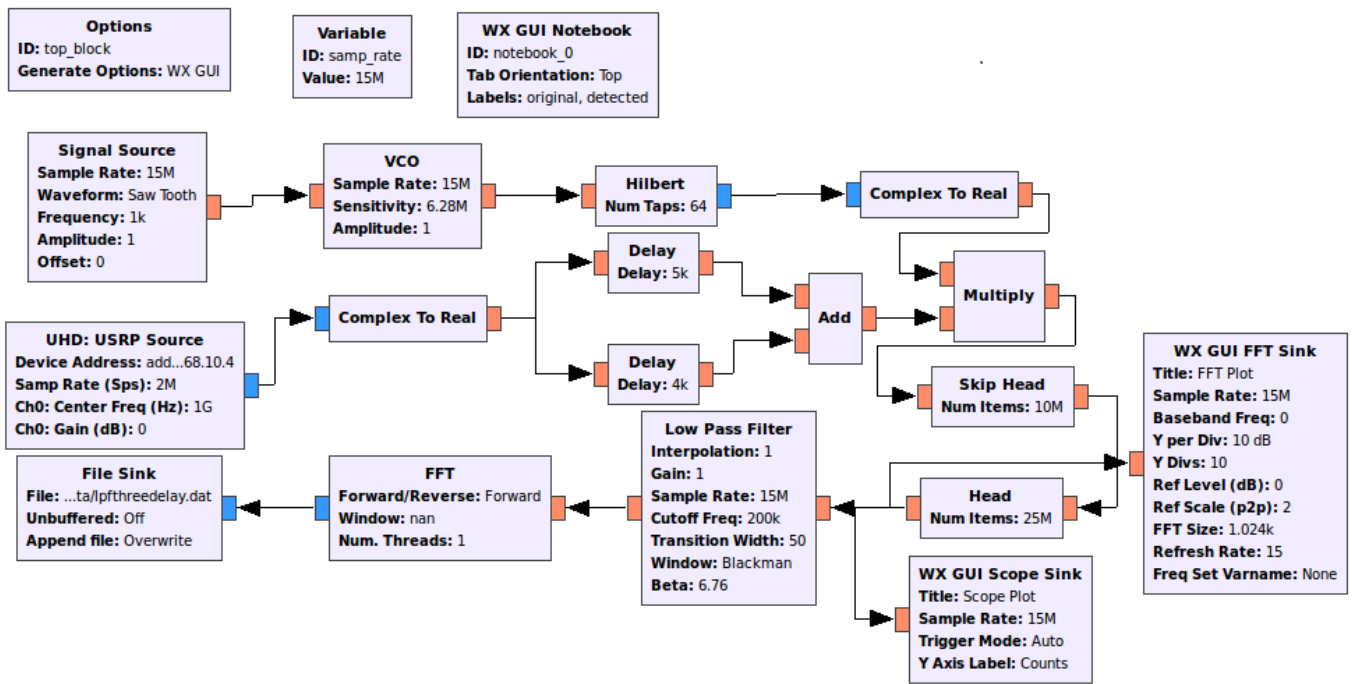

Fig. 6. GNU Radio FMCW Radar Receiver with Delay Blocks